

No.	Description	Part No.
1	Knob	09347P-15
2	Shaft Seal Nut	13145P-05
3	Volume Control	09349P-30
4	Jack Cover (with Nut)	09518P-04
5	Neoprene Washer (10/pk)	18900G-39
6	Headset Jack	09228P-03
7	Connector (4 socket)	00084M-04

No.	Description	Part No.
8	Gasket	13176P-03
9	Screws and Nuts (4 ea.)	18900G-01
10	Cap (and nylon cord)	13238P-01
11	Mounting Kit	09865P-03
12	Grommet (4 ea.)	18900G-08
13	Box	26497P-04

ELECTRICAL SCHEMATIC MODEL U3801

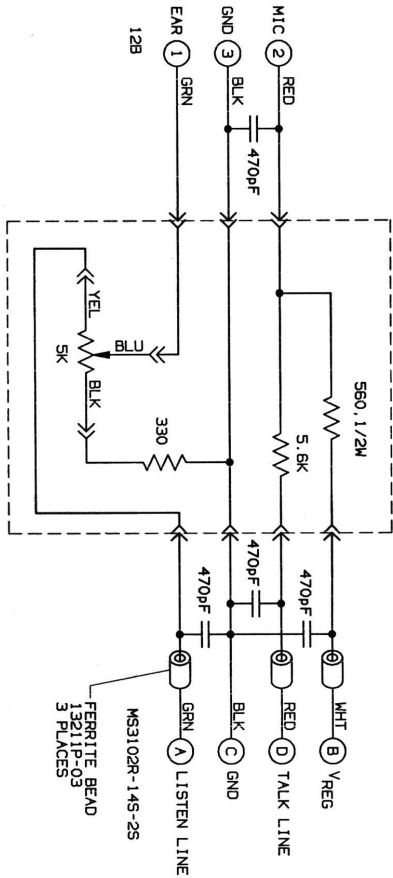

REVISIONS			
SYM	DESCRIPTION	DATE	APPROVED
A	SEE ECN 10314	17 MAR 89	BPD LFF
B	SEE ECN 12781	01 OCT 01	JD DPC

<p>NOTES:</p> <p>1. ALL RESISTORS ARE IN OHMS, 1/4 WATT, 5% TOLERANCE, UNLESS OTHERWISE SPECIFIED.</p> <p>DO NOT SCALE DRAWING</p> <p>UNLESS OTHERWISE SPECIFIED: FINAL FINISH ✓ ALL OVER</p> <p>REMOVE ALL BURRS AND BREAK SHARP EDGES</p>		<p>QTY</p> <p>SYM</p> <p>PART NO.</p> <p>DATE</p> <p>25 SEP 84</p> <p>04 OCT 84</p> <p>05 OCT 84</p> <p>15 JAN 85</p>	
<p>DRAFTER: L.E. FAIRBANKS</p> <p>CHECKER: D.A. FRATKIN</p> <p>ENG. APPROVAL: J. BERGIN</p> <p>E.J. COLLINS</p>		<p>1950SP-46 (10-01)</p>	
<p>UNLESS OTHERWISE SPECIFIED: FINAL FINISH ✓ ALL OVER</p> <p>REMOVE ALL BURRS AND BREAK SHARP EDGES</p>		<p>© 2001 David Clark Company Incorporated</p>	
<p>APPLICATION</p> <p>USED ON</p> <p>QTY REQ'D</p> <p>QTY</p> <p>SYM</p> <p>PART NO.</p> <p>DATE</p> <p>25 SEP 84</p> <p>04 OCT 84</p> <p>05 OCT 84</p> <p>15 JAN 85</p>		<p>LIST OF MATERIALS</p> <p>DESCRIPTION</p> <p>MATERIAL</p> <p>SPECIFICATION</p>	
<p>FINISH</p> <p>TOLERANCES UNLESS OTHERWISE SHOWN</p> <p>FRACTIONS DECIMALS ANGLES</p>		<p>David Clark COMPANY INC.</p> <p>WIRING DIAGRAM</p> <p>SCHEMATIC</p> <p>MODEL U3801</p> <p>WORCESTER, MA 01615-0054</p>	
<p>CODE IDENT NO. 71483</p> <p>CONTRACT NO. B</p> <p>SCALE</p> <p>VT.</p> <p>SHEET</p> <p>OF</p>		<p>DRIVING NO. EL18746G-01</p> <p>REV B</p>	